

TYPICAL ELEVATION VIEW  
SCALE: N.T.S.

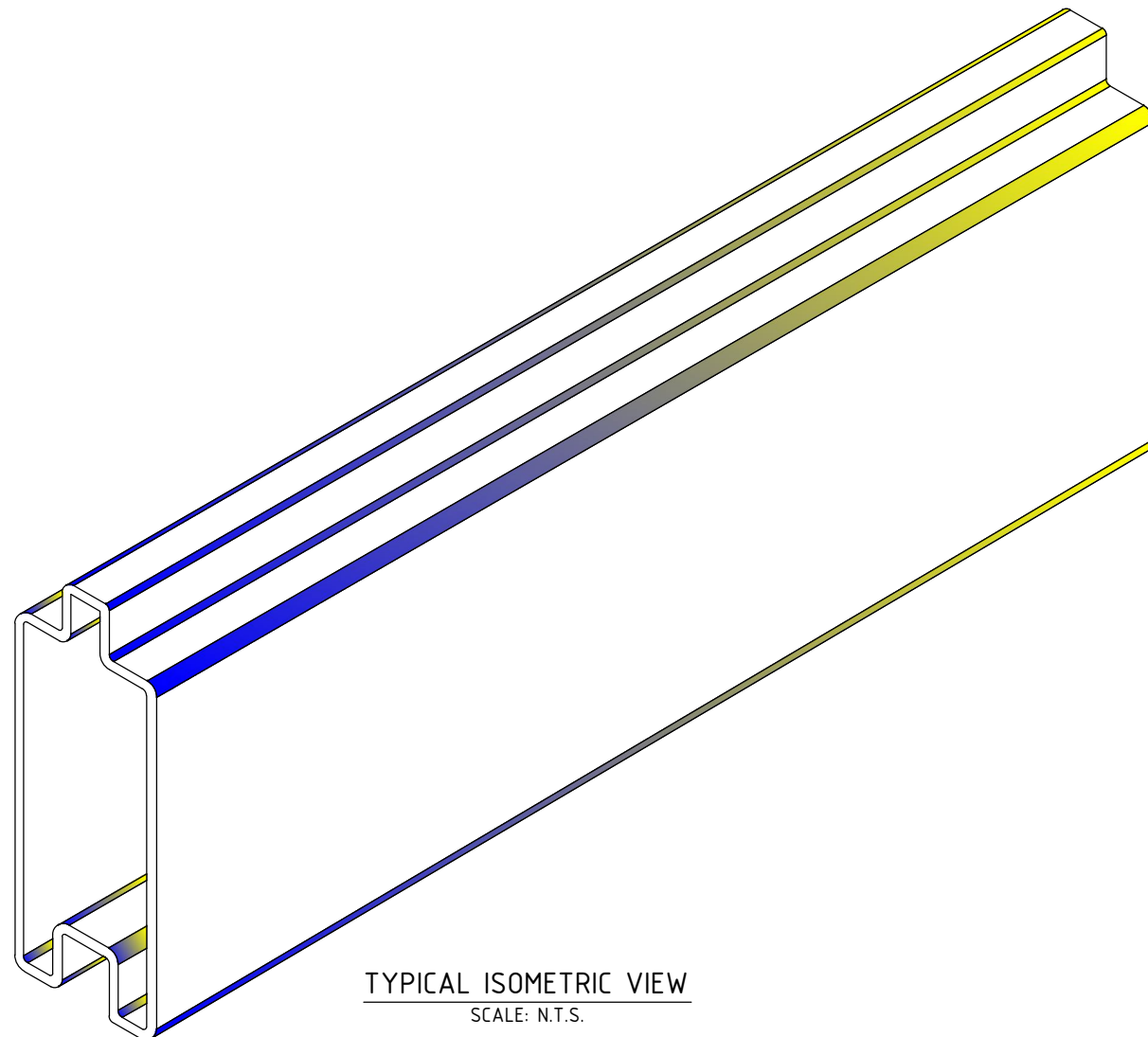

TYPICAL ISOMETRIC VIEW  
SCALE: N.T.S.

STANDARD PANEL PART LIST		
PRODUCT DESCRIPTION	LENGTH 'L'	WEIGHT *
TUF-BARRIER 95.5" PANEL	2426 mm [95.5"]	7.7 kg [17 lbs]
TUF-BARRIER 119.5" PANEL	3035 mm [119.5"]	9.7 kg [21.3 lbs]
TUF-BARRIER 143.5" PANEL	3645 mm [143.5"]	11.6 kg [25.6 lbs]
TUF-BARRIER 167.5" PANEL	4255 mm [167.5"]	13.5 kg [29.8 lbs]

NOTES:

- DIMENSIONS ARE IN MILLIMETRES [INCHES]
- TOLERANCES:
  - LENGTH  $\pm 3$  mm [ $\pm \frac{1}{16}$ "]
  - WIDTH  $\pm 0.3$  mm [ $\pm 0.01$ "]
  - HEIGHT  $\pm 0.3$  mm [ $\pm 0.01$ "]
  - BOW  $\pm 3.0$  mm [ $\pm 0.13$ "] PER SIDE
- STC=31

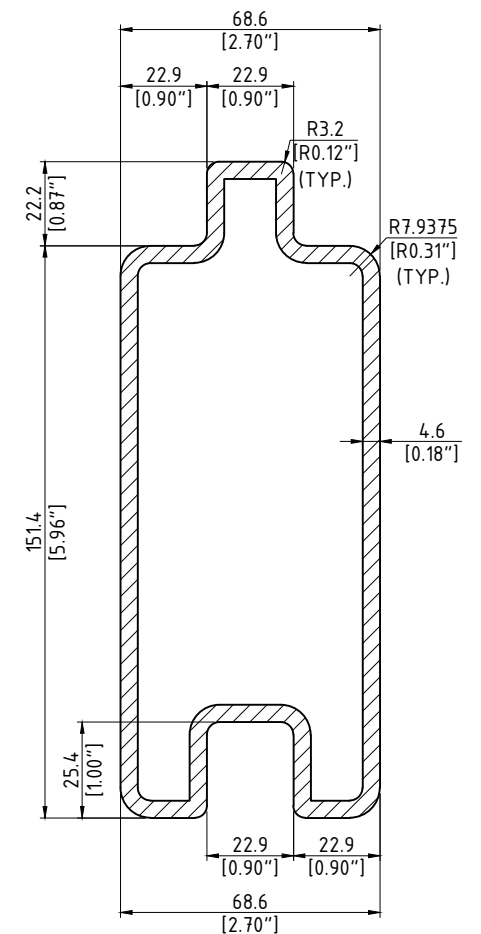

SECTION - TYPICAL CROSS SECTION  
SCALE: N.T.S.

REV NO.	DATE	BY	DESCRIPTION
1	1 DEC 16	P.S.	GENERAL REVISIONS
0	30 NOV 12	R.E.	ISSUED AS STANDARD



CALL TOLL FREE IN NORTH AMERICA  
1-866-231-7867  
www.ailsoundwalls.com www.ail.ca

SOUNDWALLS - STANDARD DRAWING  
STANDARD PANEL & STANDARD PARTS  
TUF BARRIER  
STANDARD PANEL DETAIL

DESIGNED	-	-	BRANCH P.O.	CUSTOMER REF.
DES. CHK	-	-		
DRAWN BY	R.E.	18 OCT 12	PROJECT NUMBER	STD DRAWING
DWG. CHK	P.A.S	30 NOV 12	DWG. NO.	SW-010
			REV. NO.	1

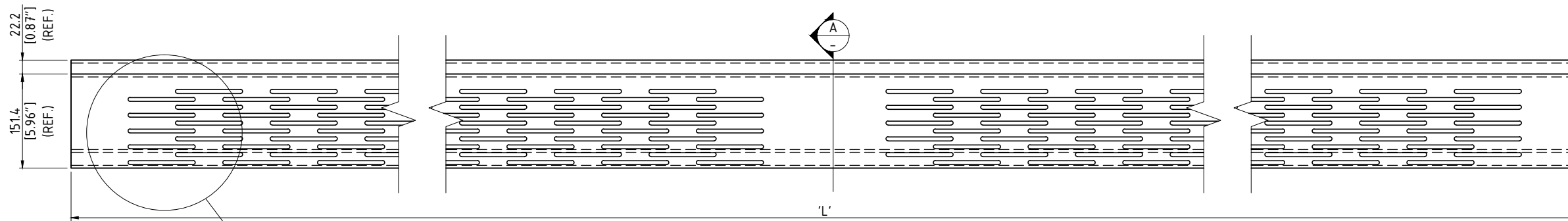

TYPICAL ELEVATION VIEW  
SCALE: N.T.S.

1  
SW-020  
DETAIL

STANDARD PANEL PART LIST		
PRODUCT DESCRIPTION	LENGTH 'L'	WEIGHT *
SILENT PROTECTOR 95.5" PANEL	2426 mm [95.5"]	7.7 kg [17 lbs]
SILENT PROTECTOR 119.5" PANEL	3035 mm [119.5"]	9.7 kg [21.3 lbs]
SILENT PROTECTOR 143.5" PANEL	3645 mm [143.5"]	11.6 kg [25.6 lbs]

- NOTES:
- DIMENSIONS ARE IN MILLIMETRES [INCHES]
  - TOLERANCES:
    - LENGTH  $\pm 3$  mm [ $\pm \frac{1}{16}$ "]
    - WIDTH  $\pm 0.3$  mm [ $\pm 0.01$ "]
    - HEIGHT  $\pm 0.3$  mm [ $\pm 0.01$ "]
    - BOW  $\pm 3.0$  mm [ $\pm 0.13$ "] PER SIDE
  - \* WEIGHT INCLUDES WEIGHT OF MINERAL FIBRE
  - STC=31, NRC=1.0



ACOUSTIC MINERAL WOOL BY ROXUL  
c/w WATER PROTECTIVE MEMBRANE ON  
THE PANEL'S PERFORATED SIDE INSTALLED  
AT MANUFACTURING FACILITY DURING  
PRODUCTION OF SILENT PROTECTOR  
PRODUCT (TYPICAL ALL PANELS)

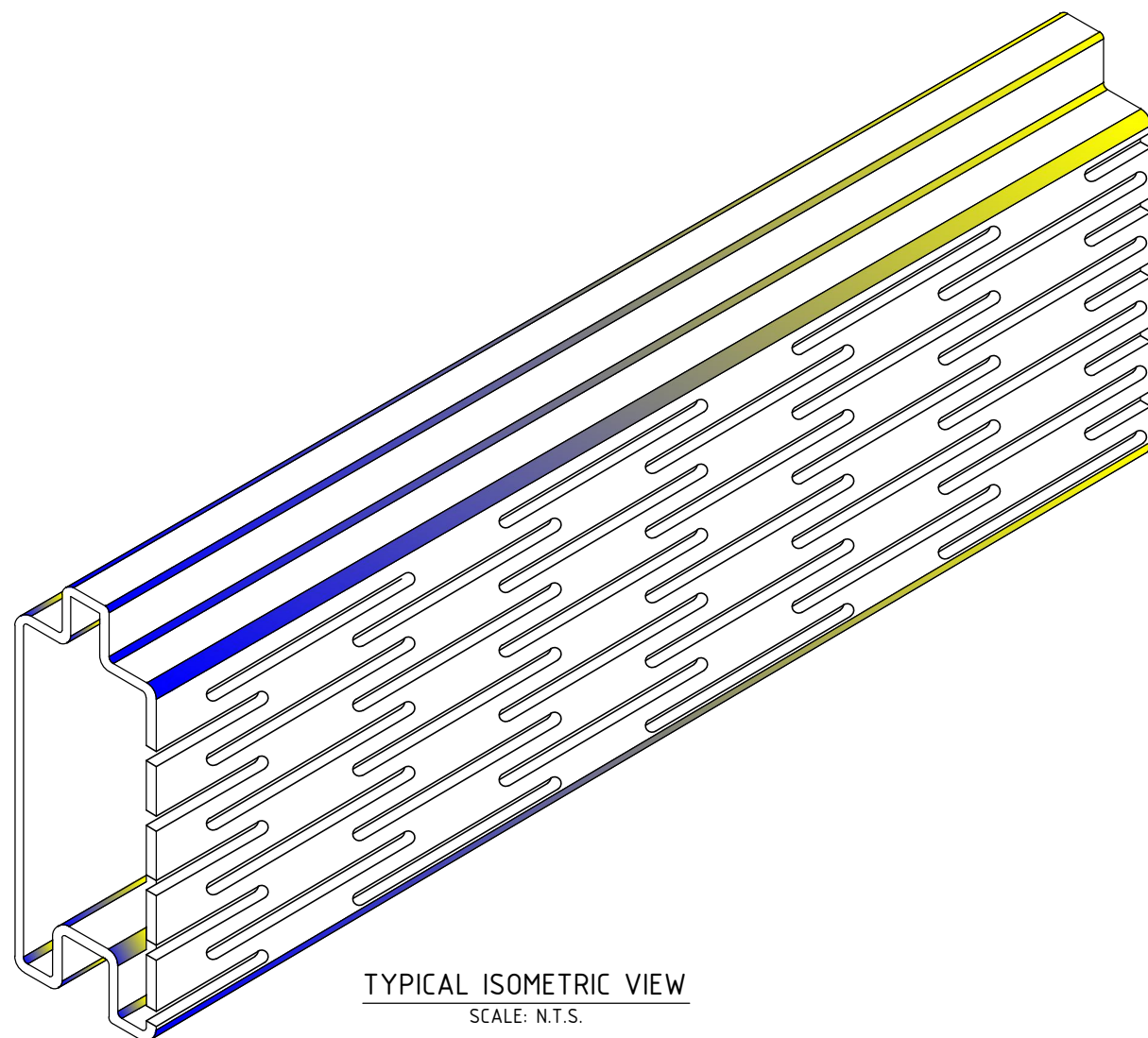

TYPICAL ISOMETRIC VIEW  
SCALE: N.T.S.

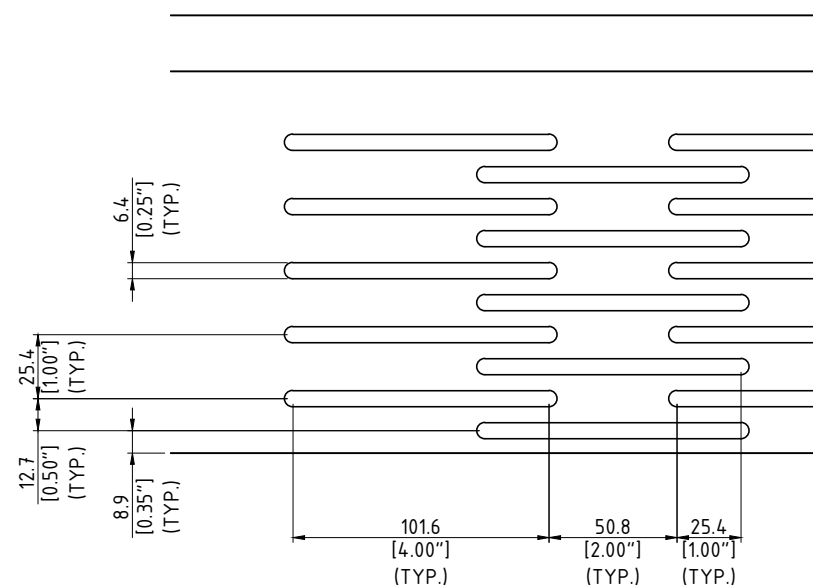

1  
SW-020  
DETAIL - ROUTING PATTERN  
SCALE: N.T.S.

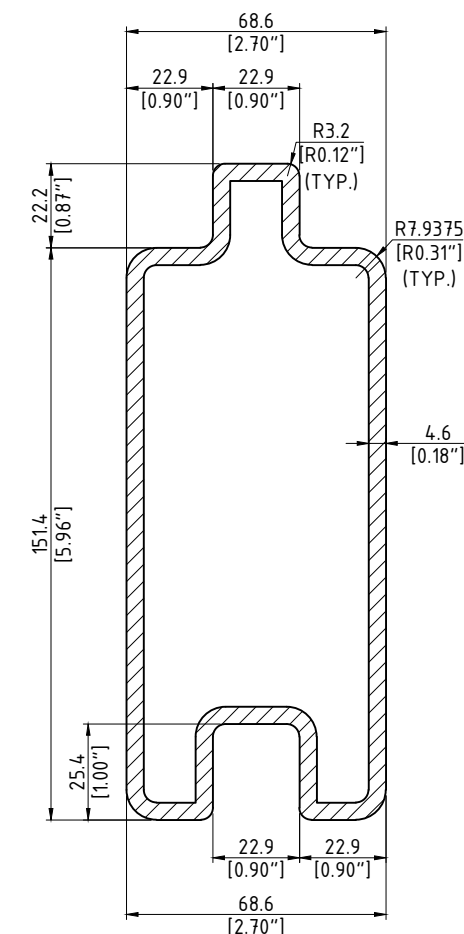

A  
SECTION - TYPICAL CROSS SECTION  
SCALE: N.T.S.

REV NO.	DATE	BY	DESCRIPTION
1	1 DEC 16	P.S.	GENERAL REVISIONS
0	30 NOV 12	R.E.	ISSUED AS STANDARD



CALL TOLL FREE IN NORTH AMERICA  
1-866-231-7867  
www.ailsoundwalls.com www.ail.ca

SOUNDWALLS - STANDARD DRAWING  
STANDARD PANEL & STANDARD PARTS  
SILENT PROTECTOR  
STANDARD PANEL DETAIL

DESIGNED -	BRANCH P.O. -	CUSTOMER REF. -
DES. CHK -		
DRAWN BY R.E.	PROJECT NUMBER	DWG. NO. SW-020
18 OCT 12	STD DRAWING	NO. SW-020
30 NOV 12		REV. 1

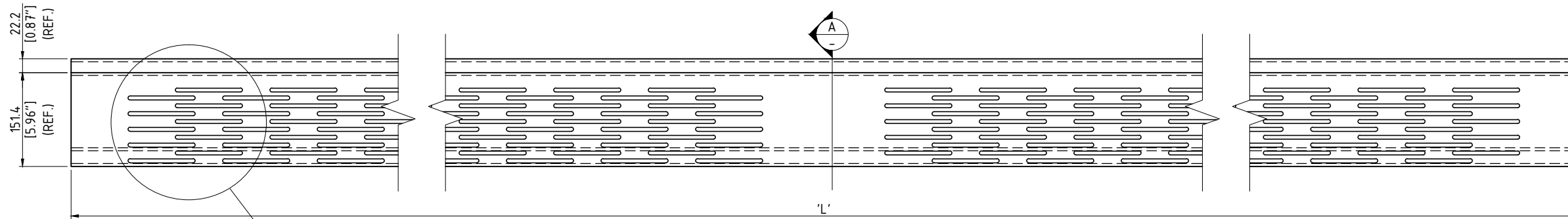

1  
SW-025  
DETAIL

TYPICAL ELEVATION VIEW  
SCALE: N.T.S.

STANDARD PANEL PART LIST		
PRODUCT DESCRIPTION	LENGTH 'L'	WEIGHT *
SILENT PROTECTOR 95.5" PANEL	2426 mm [95.5"]	13.2 kg [29.2 lbs]
SILENT PROTECTOR 119.5" PANEL	3035 mm [119.5"]	19.9 kg [36.5 lbs]
SILENT PROTECTOR PLUS 143.5" PANEL	3645 mm [143.5"]	16.6 kg [43.8 lbs]

- NOTES:
- DIMENSIONS ARE IN MILLIMETRES [INCHES]
  - TOLERANCES:
    - LENGTH  $\pm 3$  mm [ $\pm \frac{1}{16}$ "]
    - WIDTH  $\pm 0.3$  mm [ $\pm 0.01$ "]
    - HEIGHT  $\pm 0.3$  mm [ $\pm 0.01$ "]
    - BOW  $\pm 3.0$  mm [ $\pm 0.13$ "] PER SIDE
  - \* WEIGHT INCLUDES WEIGHT OF MINERAL FIBRE
  - STC=36, NRC=0.95



ACOUSTIC MINERAL WOOL BY ROXUL  
c/w WATER PROTECTIVE MEMBRANE ON  
THE PANEL'S PERFORATED SIDE INSTALLED  
AT MANUFACTURING FACILITY DURING  
PRODUCTION OF SILENT PROTECTOR  
PRODUCT (TYPICAL ALL PANELS)

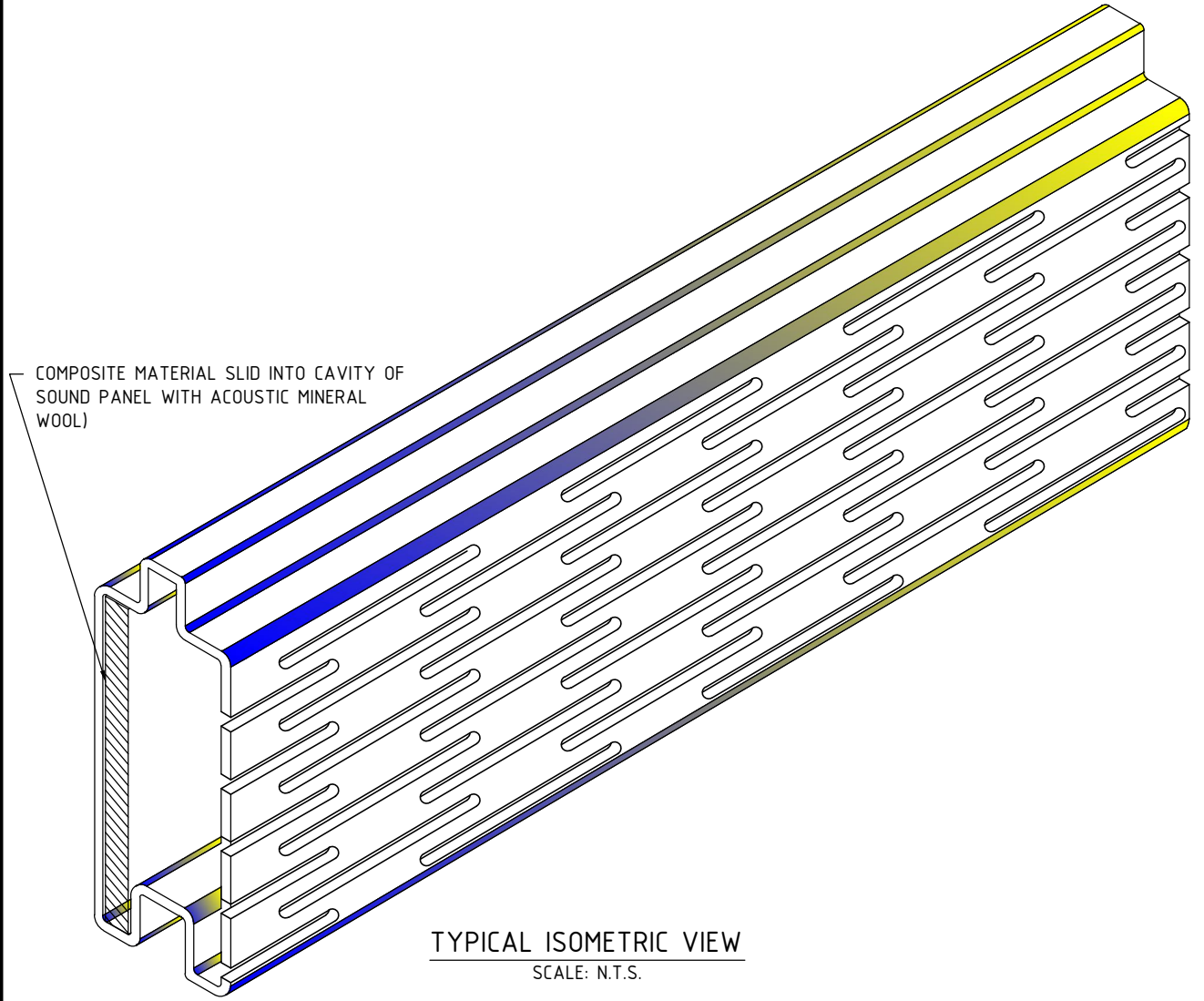

TYPICAL ISOMETRIC VIEW  
SCALE: N.T.S.

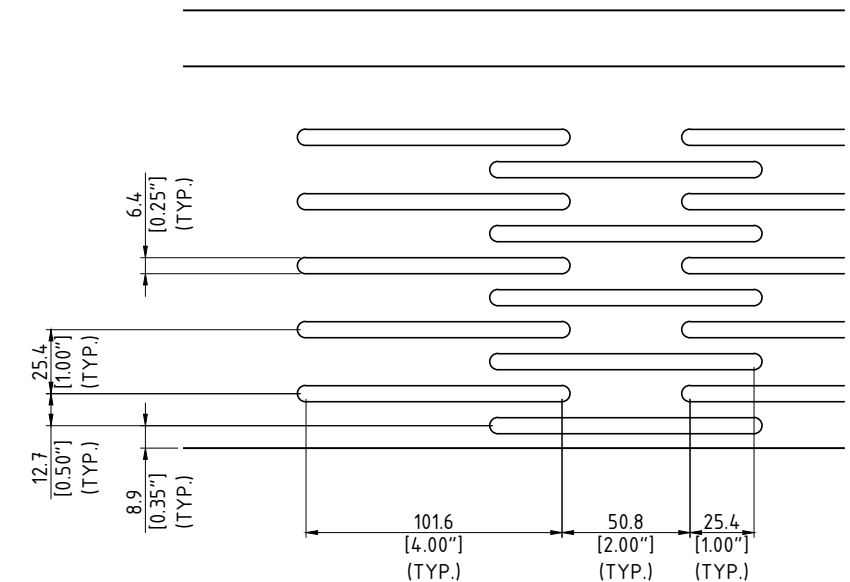

1  
SW-025  
DETAIL - ROUTING PATTERN  
SCALE: N.T.S.

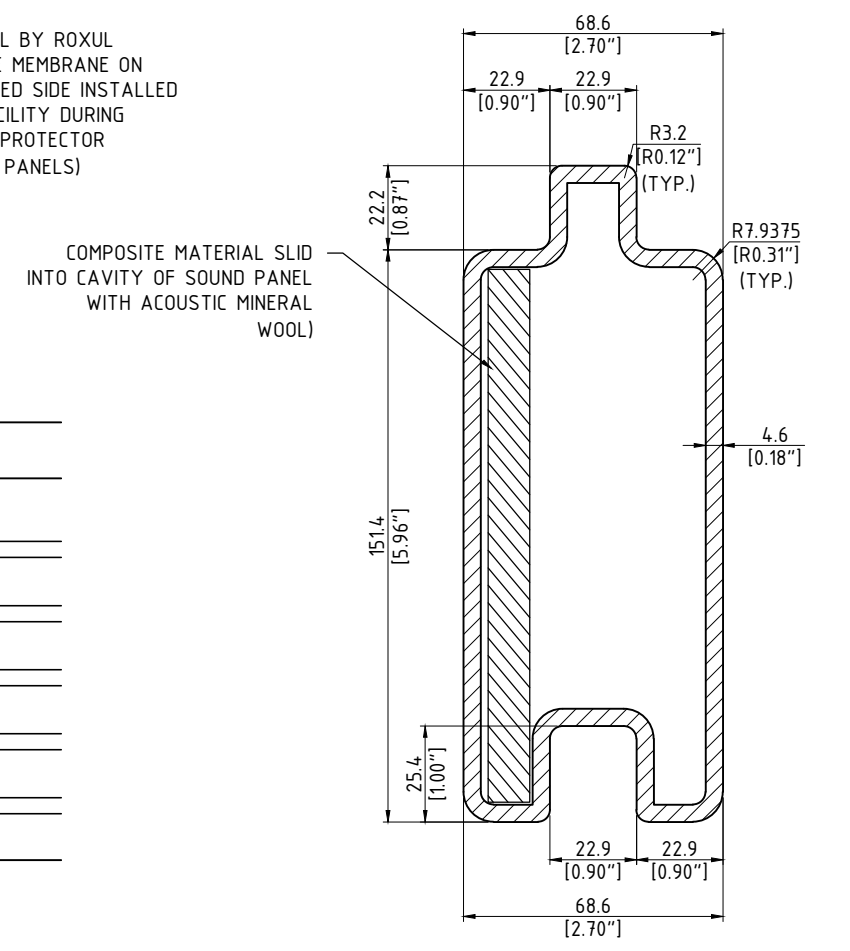

A  
SECTION - TYPICAL CROSS SECTION  
SCALE: N.T.S.

REV NO.	DATE	BY	DESCRIPTION
1	1 DEC 16	P.S.	GENERAL REVISIONS
0	17 SEP 15	P.S.	ISSUED AS STANDARD



CALL TOLL FREE IN NORTH AMERICA  
1-866-231-7867  
www.ailsoundwalls.com www.ail.ca

SOUNDWALLS - STANDARD DRAWING  
STANDARD PANEL & STANDARD PARTS  
SILENT PROTECTOR PLUS  
STANDARD PANEL DETAIL

DESIGNED - -	BRANCH P.O. -	CUSTOMER REF. -
DES. CHK - -		
DRAWN BY R.E.	18 OCT 12	PROJECT NUMBER
DWG. CHK P.A.S	30 NOV 12	STD DRAWING
		DWG. NO. SW-025
		REV. 1

NOTES:  
1. DIMENSIONS ARE IN MILLIMETRES [INCHES]

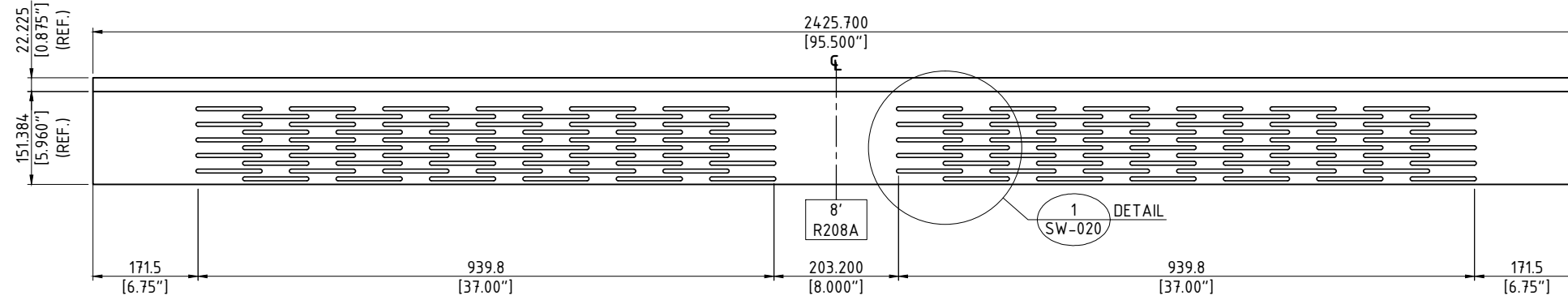

SILENT PROTECTOR ROUTING PATTERN R208A - 2.426 m [95.5"] SECTION  
SCALE: N.T.S.

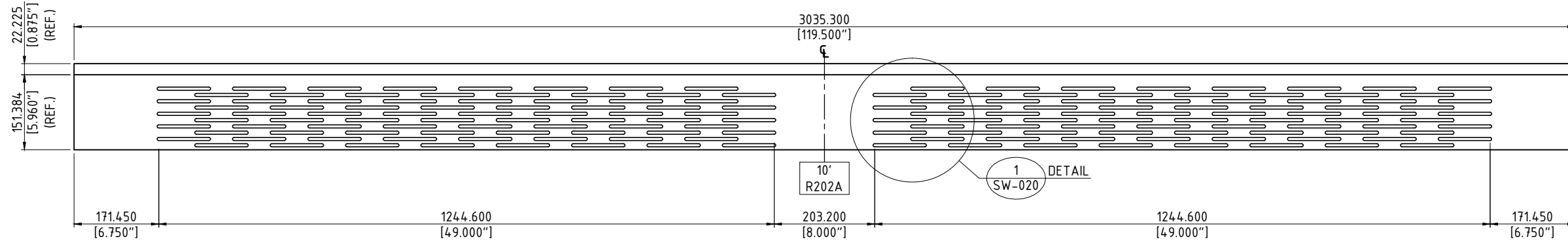

SILENT PROTECTOR ROUTING PATTERN R210A - 3.035 m [119.5"] SECTION  
SCALE: N.T.S.

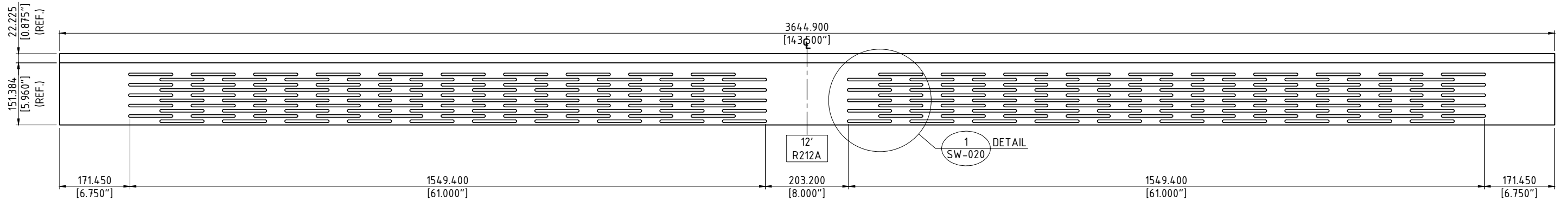

SILENT PROTECTOR ROUTING PATTERN R212A - 3.645 m [143.5"] SECTION  
SCALE: N.T.S.

2	1 DEC 16	P.S.	GENERAL REVISIONS
1	17 SEP 15	P.S.	RE-ISSUED AS STANDARD
0	30 NOV 12	R.E.	ISSUED AS STANDARD
REV NO.	DATE	BY	DESCRIPTION



CALL TOLL FREE IN NORTH AMERICA  
1-866-231-7867  
www.ailsoundwalls.com www.ail.ca

SOUNDWALLS - STANDARD DRAWING  
STANDARD PANEL & STANDARD PARTS  
SILENT PROTECTOR  
STANDARD PANEL ROUTING DETAILS

DESIGNED	-	-	BRANCH P.O.	CUSTOMER REF.
DES. CHK	-	-	-	-
DRAWN BY	R.E.	18 OCT 12	PROJECT NUMBER	STD DRAWING
DWG. CHK	P.A.S	30 NOV 12	DWG. NO.	SW-030
			REV. NO.	1

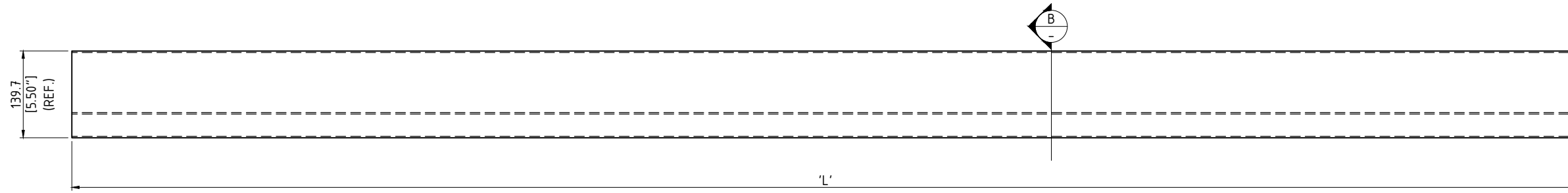

TYPICAL ELEVATION VIEW  
SCALE: N.T.S.

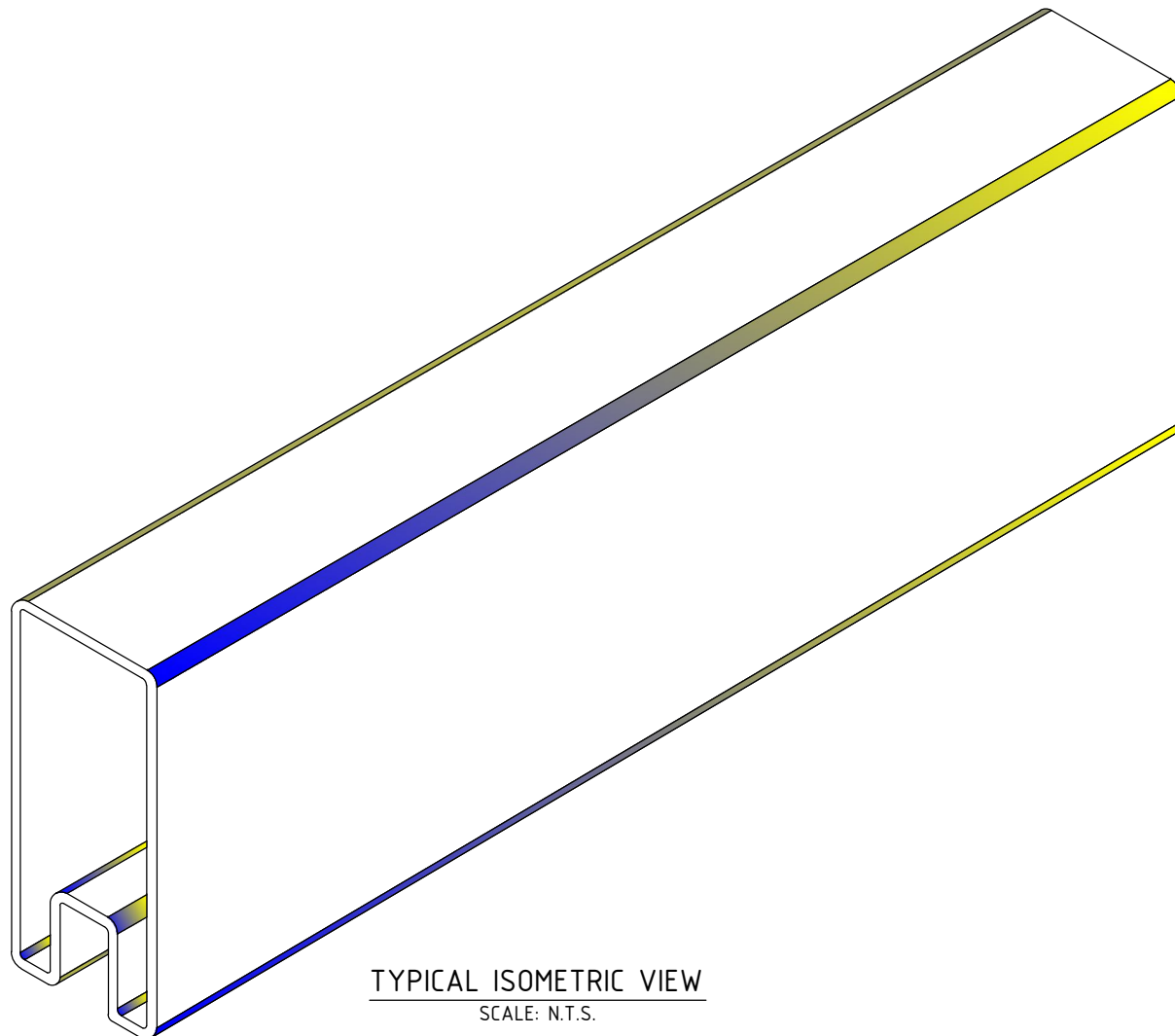

TYPICAL ISOMETRIC VIEW  
SCALE: N.T.S.

STANDARD PANEL PART LIST		
PRODUCT DESCRIPTION	LENGTH 'L'	WEIGHT
TOP RAIL 95.5	2426 mm [95.5"]	4.1 kg [9.0 lbs]
TOP RAIL 119.5	3035 mm [119.5"]	5.0 kg [11.0 lbs]
TOP RAIL 143.5	3645 mm [143.5"]	6.0 kg [13.2 lbs]
TOP RAIL 167.5	4255 mm [167.5"]	7.0 kg [15.4 lbs]

NOTES:

- DIMENSIONS ARE IN MILLIMETRES [INCHES]
- TOLERANCES:
  - LENGTH  $\pm 3$  mm [ $\pm \frac{1}{16}$ "]
  - WIDTH  $\pm 0.3$  mm [ $\pm 0.01$ "]
  - HEIGHT  $\pm 0.3$  mm [ $\pm 0.01$ "]
  - BOW  $\pm 3.0$  mm [ $\pm 0.13$ "] PER SIDE

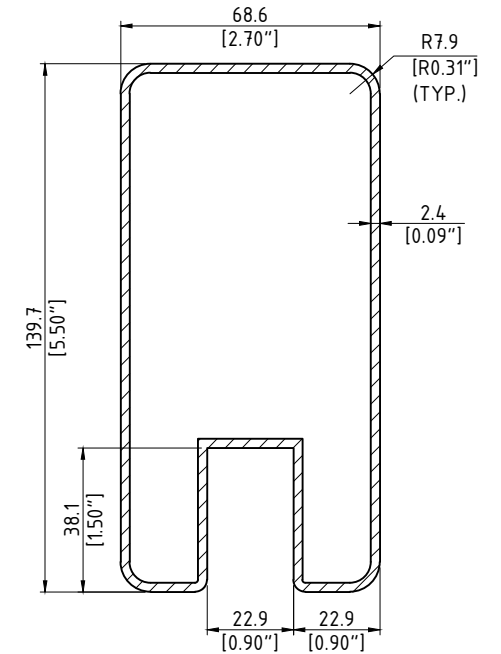

SECTION - TYPICAL CROSS SECTION  
SCALE: N.T.S.

REV NO.	DATE	BY	DESCRIPTION
1	1 DEC 16	P.S.	GENERAL DESCRIPTION
0	30 NOV 12	R.E.	ISSUED AS STANDARD



CALL TOLL FREE IN NORTH AMERICA  
1-866-231-7867  
www.ailsoundwalls.com www.ail.ca

SOUNDWALLS - STANDARD DRAWING  
STANDARD PANEL & STANDARD PARTS  
TOP RAIL  
STANDARD PANEL DETAIL

DESIGNED	-	-	BRANCH P.O.	CUSTOMER REF.
DES. CHK	-	-	-	-
DRAWN BY	R.E.	18 OCT 12	PROJECT NUMBER	STD DRAWING
DWG. CHK	P.A.S	30 NOV 12	DWG. NO.	SW-040
			REV.	1

STANDARD PANEL PART LIST		
PRODUCT DESCRIPTION	LENGTH 'L'	WEIGHT
STEEL C-CHANNEL 95	2413 mm [95"]	8.1 kg [17.9 lbs]
STEEL C-CHANNEL 119	2023 mm [119"]	10.2 kg [22.5 lbs]
STEEL C-CHANNEL 143	3632 mm [143"]	12.3 kg [27.0 lbs]
STEEL C-CHANNEL 167	4242 mm [167"]	14.3 kg [31.5 lbs]

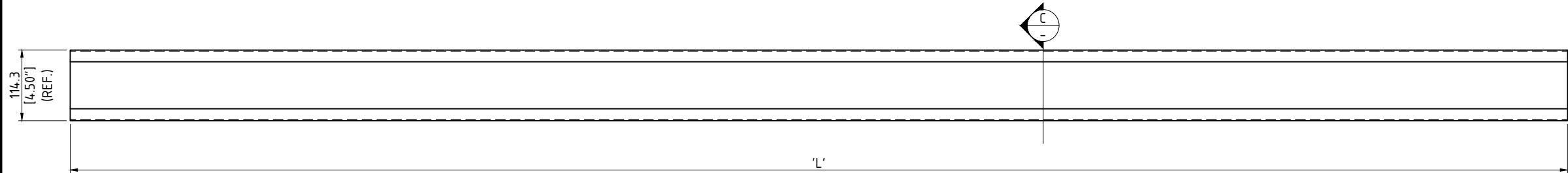

TYPICAL ELEVATION VIEW  
SCALE: N.T.S.

- NOTES:
- DIMENSIONS ARE IN MILLIMETRES [INCHES]
  - TOLERANCES:
    - LENGTH  $\pm 3$  mm [ $\pm \frac{1}{16}$ "]
    - WIDTH  $\pm 1.5$  mm [ $\pm 0.06$ "]
    - HEIGHT  $\pm 1.5$  mm [ $\pm 0.06$ "]
    - BOW  $\pm 3.0$  mm [ $\pm 0.13$ "] PER SIDE
  - STEEL CHANNEL SHALL BE MANUFACTURED FROM STEEL MEETING ASTM A653 SS Fy 345 MPa (GRADE 50)

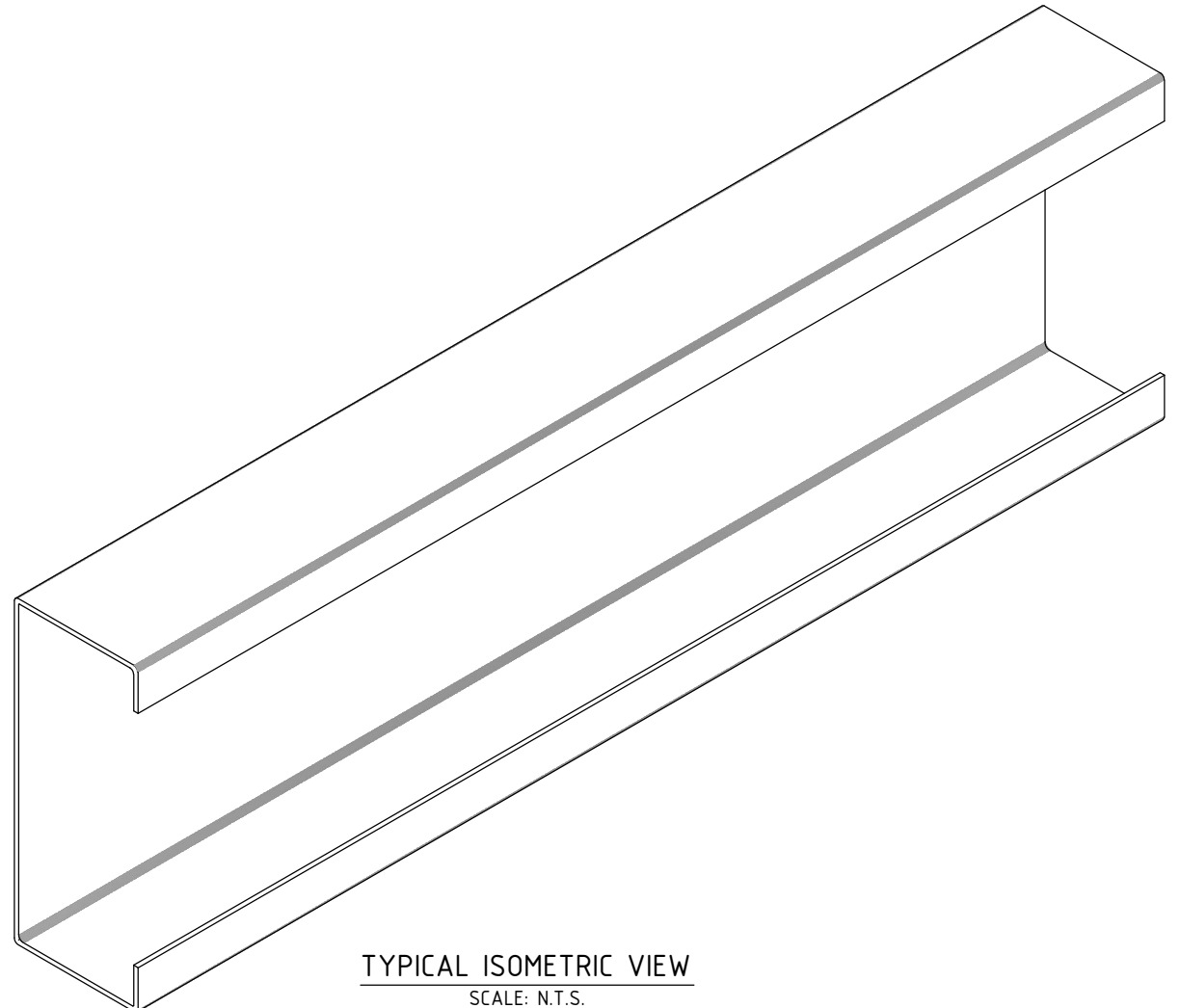

TYPICAL ISOMETRIC VIEW  
SCALE: N.T.S.

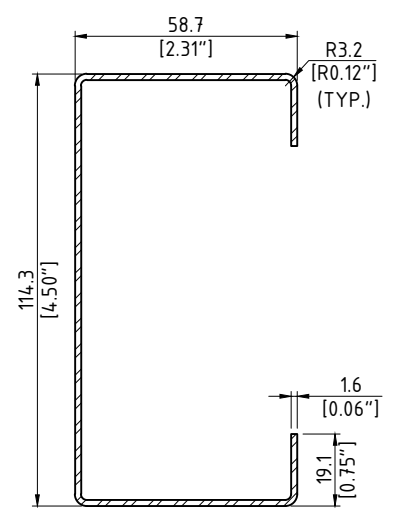

SECTION - TYPICAL CROSS SECTION  
SCALE: N.T.S.

REV NO.	DATE	BY	DESCRIPTION
1	1 DEC 16	P.S.	GENERAL REVISION
0	30 NOV 12	R.E.	ISSUED AS STANDARD



CALL TOLL FREE IN NORTH AMERICA  
1-866-231-7867  
www.ailsoundwalls.com www.ail.ca

SOUNDWALLS - STANDARD DRAWING  
STANDARD PANEL & STANDARD PARTS  
STEEL SUPPORT CHANNEL  
STANDARD DETAIL

DESIGNED	-	-	BRANCH P.O.	-	CUSTOMER REF.	-
DES. CHK	-	-				
DRAWN BY	R.E.	18 OCT 12	PROJECT NUMBER	STD DRAWING	DWG NO.	SW-050
DWG. CHK	P.A.S	30 NOV 12			REV.	1

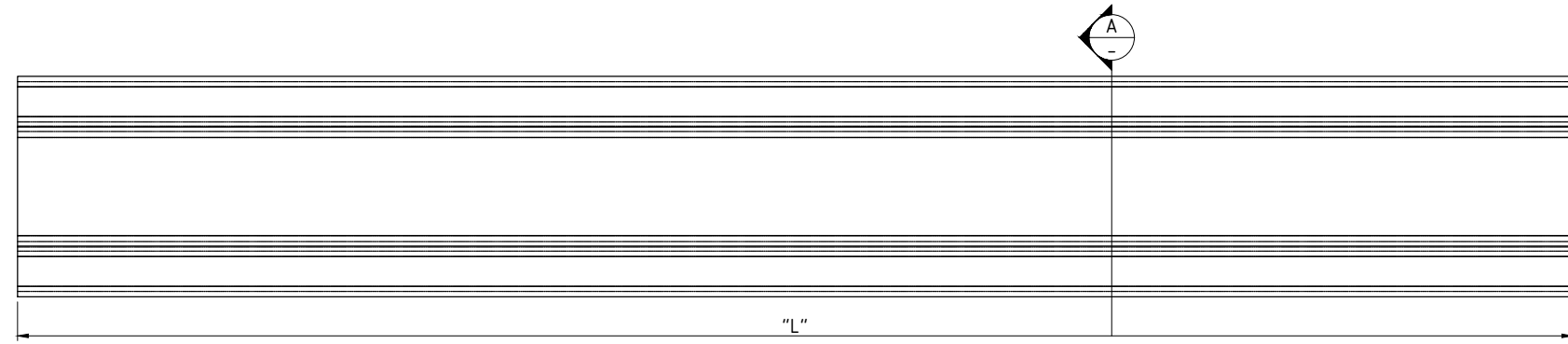

TYPICAL ELEVATION VIEW  
SCALE: N.T.S.

STANDARD PANEL PART LIST		
PRODUCT DESCRIPTION	LENGTH 'L'	WEIGHT *
H-POST 84	2234mm [84"]	6.3 kg [14 lbs]
H-POST 108	2744mm [108"]	8.1 kg [18 lbs]

NOTES:

- DIMENSIONS ARE IN MILLIMETRES [INCHES]
- TOLERANCES:
  - LENGTH  $\pm 3$  mm [ $\pm \frac{1}{8}$ "]
  - WIDTH  $\pm 0.25$  mm [ $\pm 0.01$ "]
  - HEIGHT  $\pm 0.25$  mm [ $\pm 0.01$ "]
  - BOW  $\pm 6.0$  mm [ $\pm 0.25$ "] PER SIDE

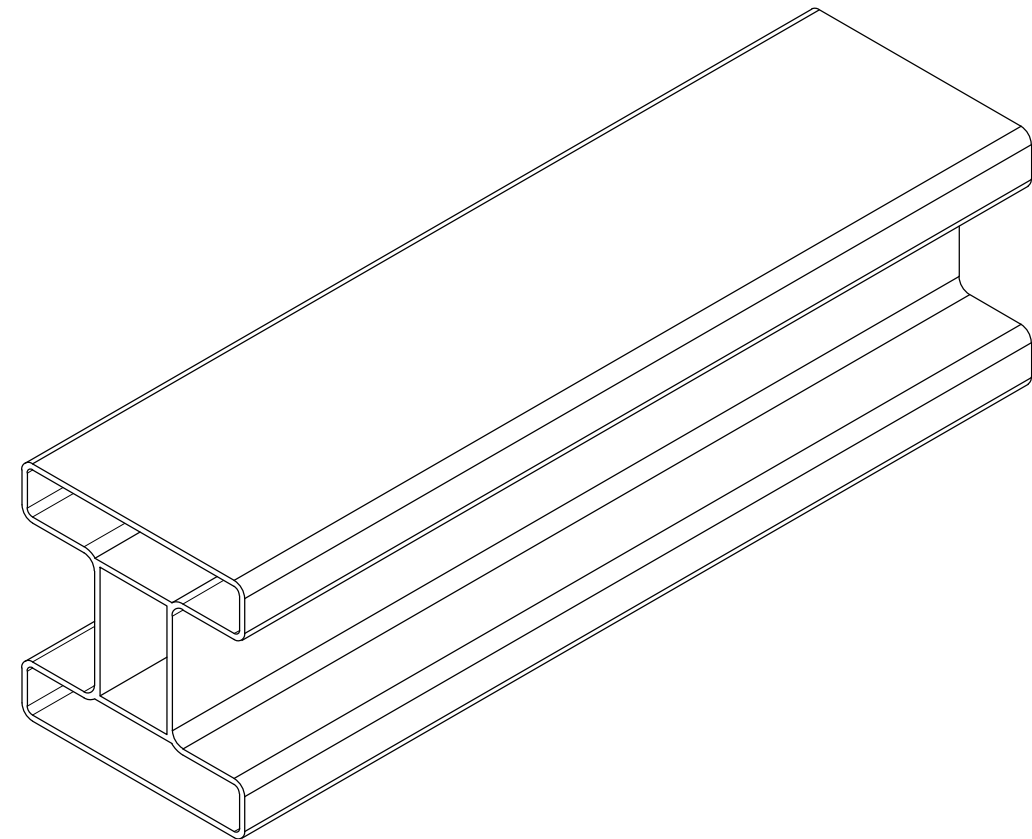

TYPICAL ISOMETRIC VIEW  
SCALE: N.T.S.

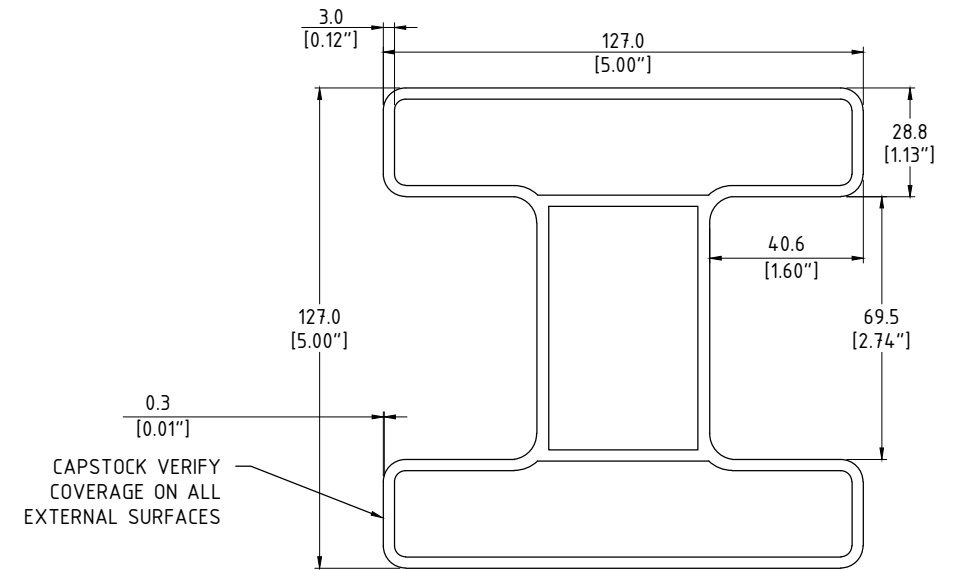

SECTION - TYPICAL CROSS SECTION  
SCALE: N.T.S.

REV NO.	DATE	BY	DESCRIPTION
0	29 APR 15	TM	ISSUED AS STANDARD



CALL TOLL FREE IN NORTH AMERICA  
1-866-231-7867  
www.ailsoundwalls.com www.ail.ca

SOUNDWALLS - STANDARD DRAWING  
STANDARD PANEL & STANDARD PARTS  
H-POST DETAILS

DESIGNED	-	-	BRANCH P.O.	CUSTOMER REF.
DES. CHK	-	-	-	-
DRAWN BY	R.E.	18 OCT 12	PROJECT NUMBER	STD DRAWING
DWG. CHK	P.A.S	30 NOV 12	DWG. NO.	SW-060
			REV.	0